



# SY80U

High efficient and stable  
A multi-purpose machine

Fully Change **QUALITY**  
CHANGES THE WORLD



## SELLING POINTS

### ● Flexible Operation

High efficiency load sensitive system, minimum working device turning radius, deflective boom, flexible operation.

### ● Stable & Reliable

Imported engines, high strength structural parts, excellent lifting capacity, reliable work

### ● Various Configuration

Quick couple pipelines, two units of auxiliary pipelines, multi-function hand levers, various accessories could be equipped.

### ● Safety & Comfortable

Suspension seat, silicone oil shock absorber, airconditioner, LED lights, working comfortably.

## Machine Dimensions (mm)

Standard

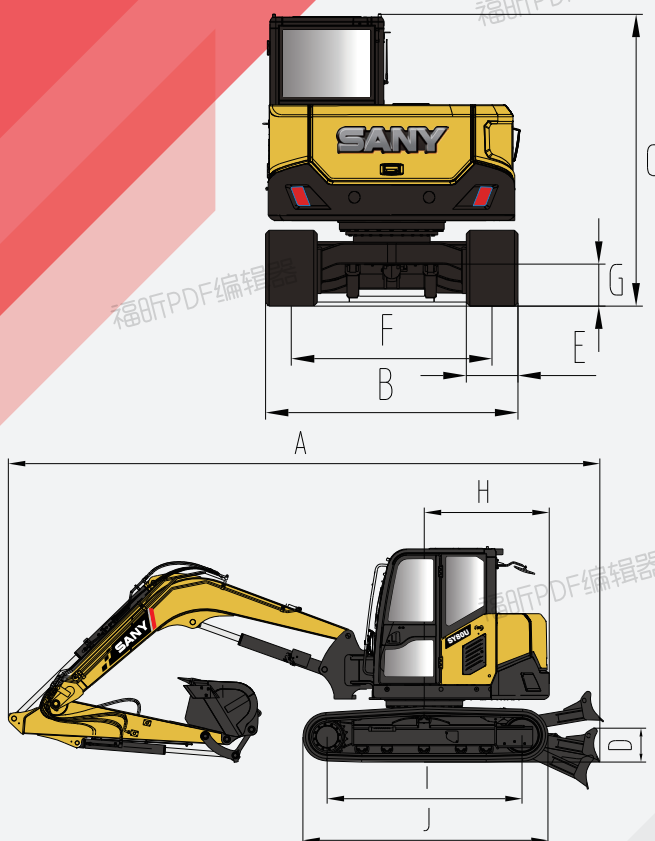

	SY80U
A Overall length(in transportation)	7010
B Overall width(in transportation)	2200
C Overall height(in transportation)	2550
D Bulldozer plate height	410
E Standard track width	450
F Track gauge(in transportation)	1750
G Minimum ground clearance	365
H Slewing radius of tail	1480
I Wheel gauge	2315
J Track length	2915

## Performance parameters

Standard

	SY80U
Operation weight kg	8800
Bucket capacity m <sup>3</sup>	0.28
Rated power KW/rpm	53.7/2100
Traveling speed(high/low) km/h	4.5/2.5
Slewing speed rpm	10
Gradeability	70%/35°
Ground pressure kPa	37.9
Digging force of bucket kN	72.7
Digging force of arm kN	40.5

## Operation range (mm)

Standard

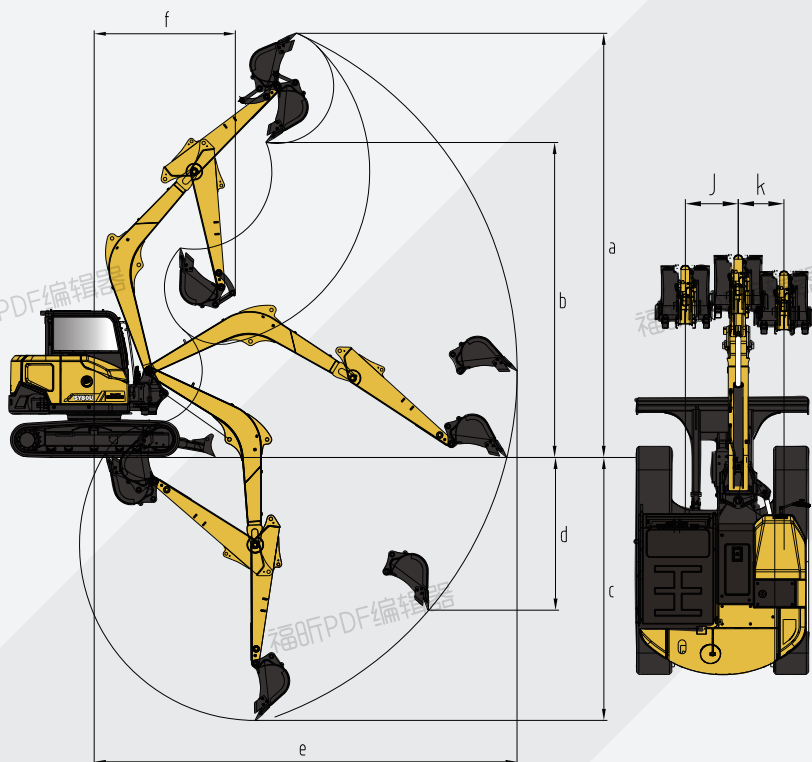

	SY80U
a Maximum digging height	7315
b Maximum unloading height	5430
c Maximum digging depth	4535
d Maximum digging depth with vertical boom	2490
e Maximum digging distance	7290
f Maximum slewing radius	2435
g Maximum height at maximum slewing radius	5490
h Maximum ground clearance with bulldozer plate lifted up	480
i Maximum cutting depth of bulldozer plate	325
j Left deflective distance of boom	675
k Right deflective distance of boom	585

## SANY Heavy Machinery Co.,LTD

SANY Industrial Park,Dongcheng Avenue,  
Economic & Technical Development Zone,  
KUNSHAN City, Jiangsu Province

Zip code: 215300

Service hotline: 4008-28-2318

Complaint hotline: 4008-87-9318

Website: <http://www.sanygroup.com>



## Note

Due to continuous technical updates, materials and specifications are subject to change without prior notice. The machine in the picture may include additional equipment.

ZJSYX0604CH

Printed in CHINA